

# RIS V



AHU with heat recovery

Rekuperatoriniai įrenginiai

Centrale wentylacyjne z odzyskiem ciepła

Вентиляционные агрегаты с рекуперацией тепла



Air handling units RIS V 3.0 have high efficiency plate heat exchanger. AHU is used for ventilation of houses and other heated areas.

- Efficient, low noise fans.
- Efficiency of plate heat exchanger up to 65%.
- Electrical or water heater.
- Controlled air flow.
- Anti-freeze protection of the heat exchanger.
- Low noise level.
- Every unit is tested.
- RIS 260V - 1900V 3.0 all versions can be controlled with Flex, Stouch remote control devices.
- Acoustic insulation of the walls RIS 260V 3.0 - 20 mm, RIS 400V, 700V 3.0 - 30mm, RIS 1000V, 1500V, 1900V 3.0 - 50 mm.
- RIS 260V - 1900V 3.0 housing: powder coated painting RAL 7040.
- Easy mounting.



Vėdinimo įrenginiai RIS V 3.0 pagaminti su efektyviu plokštelinei srautų šilumokaičiu. Rekuperatoriai montuojami vėdinti šildomas patalpas.

- Energiją taupantys ir tyliai dirbantys ventiliatoriai.
- Efektyvus plokštelinis šilumokaitis, kurio gražinama šiluma iki 65%.
- Elektrinis arba papildomai užsakomas kanalinis vandeninis šildytuvas.
- Keičiamas oro srautas.
- Tiekiamo oro temperatūros valdymas.
- Priešužšaliminė šilumokaičio apsauga.
- Žemas triukšmo lygis.
- Galima valdyti su Flex, Stouch pulteliais.
- Sienelių triukšmo izoliacija – RIS 260V 3.0 - 20 mm, RIS 400V, 700V 3.0- 30mm, RIS 1000V 3.0, 1500V 3.0, 1900V 3.0 - 50 mm.
- Milteliniu būdu dažytas korpusas - spalva RAL 7040.
- Greitas ir lengvas montavimas.



Centrale wentylacyjne z odzyskiem ciepła – RIS V 3.0  
Centrale wentylacyjne RIS V 3.0 są wyposażone w krzyżowy wymiennik ciepła. Przeznaczone są do wentylacji ogrzewanych pomieszczeń.

- Układ centrali - pionowa.
- Wymiennik krzyżowy wykonany w całości z aluminium.
- Energooszczędne i ciche wentylatory AC.
- Zabezpieczenie wymiennika nagrzewnicą elektryczną lub BY-PASS.
- Zabudowane nagrzewnice elektryczne wtórne lub wodne (czasami - montowane na kanale).
- Zmiana wydatku (3 biegi).
- Zmiana temperatury powietrza nawiewanego.
- Możliwość sterownia sterownikami Flex, Stouch.
- Izolacja wełną mineralną 20 mm, 30 mm lub 50 mm.
- Obudowa malowana proszkowo (RAL 7040).



Установки с рекуперацией тепла RIS V 3.0 очищают, нагревают и подают свежий воздух. Установки RIS извлекают тепло у выходящего воздуха и передают его поступающему воздуху.

- Производительные и бесшумные вентиляторы.
- Пластинчатый теплообменник, эффективность теплоотдачи до 65%.
- Электрический или водяной нагреватель.
- Регулируемый воздушный поток.
- Регулируемая температура подаваемого воздуха.
- Защита теплообменника от замерзания.
- Низкий уровень шума.
- Каждый агрегат проверен отдельно.
- RIS 260V - 1900V 3.0 с интегрированными возможностями управления и наблюдения с помощью пультов управления Flex, Stouch.
- Акустическая изоляция стенок RIS 260V 3.0- 20 мм, RIS 400V 3.0, 700V 3.0 - 30мм, RIS 1000V 3.0, 1500V 3.0, 1900V 3.0- 50 мм.
- RIS 260V 3.0 - 1900V 3.0 корпус: окрашенный RAL 7040.
- Легко монтируются.

## Accessories

Control panel	Sensor controller	Circular duct silencer	Shuft-off damper	Mounting clamp	Heating coil	Actuator for dampers
						
Flex p. 178	Stouch p. 179	AKS p. 230	SKG p. 226	AP p. 229	AVS p. 192	SP p. 188

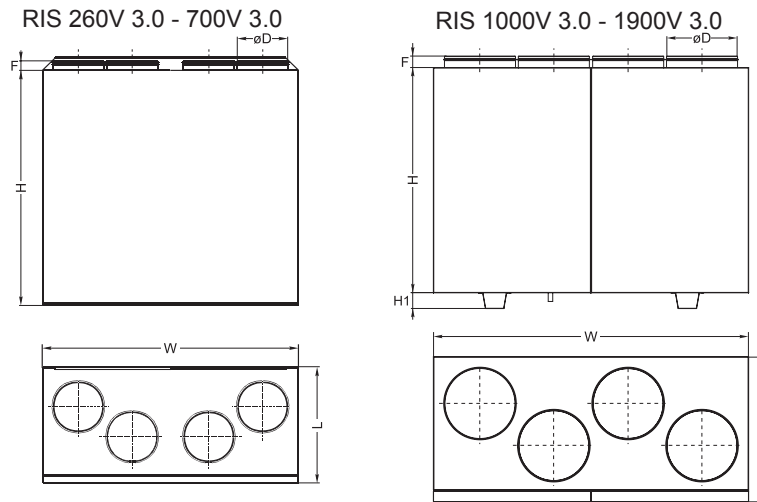

## RIS 260 V E L 3.0

- Equipped with new PRV V1.1 control board
- Air intake side (L - left; R - right)
- Heater type (E - integrated electrical heater; W - optional water heater)
- Housing type (V - vertical, H - horizontal, P - under - ceiling)
- AHU size according to air flow range m<sup>3</sup>/h
- AHU with plate heat-exchanger

Type	Dimensions [mm]					
	L	W	H	øD	H <sub>1</sub>	F
RIS 260VE/VW 3.0	295	598	680	125	-	30
RIS 400VE/VW 3.0	352	900	800	160	-	30
RIS 700VE/VW 3.0	462	950	845	200	-	30
RIS 1000VE/VW 3.0	645	1400	1000	315	145	40
RIS 1500VE/VW 3.0	645	1400	1000	315	145	40
RIS 1900VE/VW 3.0	790	1650	1100	400	70	65

Type	Accessories									
	Flex Stouch	AKS SKG AP	AVS	SP	TJP 10K CO4C***	SSB Heating	RMG 80/60°C	RMG 60/40°C	VVP/VXP 80/60°C	VVP/VXP 60/40°C
RIS 260VE 3.0	+	125	-	LM230A-TP	-	-	-	-	-	-
RIS 260VW 3.0	+	125	125	TF230	+	81	3-0,63-4	3-0,63-4	45.10-0,63	45.10-0,63
RIS 400VE 3.0	+	160	-	LM230A-TP	-	-	-	-	-	-
RIS 400VW 3.0	+	160	160	TF230	+	81	3-0,63-4	3-0,63-4	45.10-0,63	45.10-0,63
RIS 700VE 3.0	+	200	-	LM230A-TP	-	-	-	-	-	-
RIS 700VW 3.0	+	200	200	TF230	+	81	3-0,63-4	3-0,63-4	45.10-0,63	45.10-0,63
RIS 1000VE 3.0	+	315	-	LM230A-TP	-	-	-	-	-	-
RIS 1000VW 3.0	+	315	int	LF230	int	81	3-1,0-4	3-0,63-4	45.10-1,0	45.10-0,63
RIS 1500VE 3.0	+	315	-	LM230A-TP	-	-	-	-	-	-
RIS 1500VW 3.0	+	315	int	LF230	int	81	3-1,0-4	3-0,63-4	45.10-1,0	45.10-0,63
RIS 1900VE 3.0	+	400	-	SM230A-TP	-	-	-	-	-	-
RIS 1900VW 3.0	+	400	int	SF230A	int	81	3-1,6-4	3-1,0-4	45.10-1,6	45.10-1,0

\*\*\* - anti-frost thermostat  
int - already integrated into the unit

## Accessories

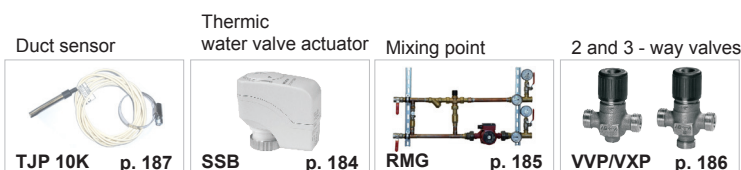

# RIS V

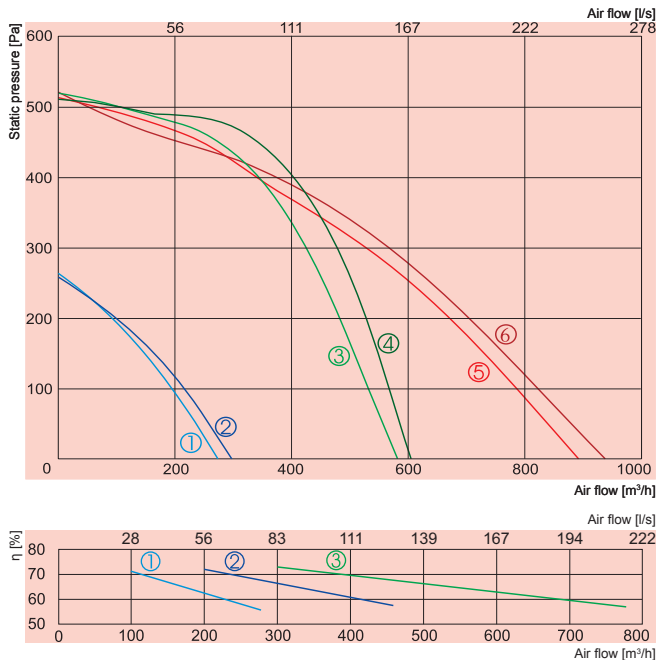

Calculated temperature efficiency (balanced mass flow) EN 13141-7:  
 Extract air = 20°C/60%RH  
 Outdoor air = -20°C

- ① — supply **RIS 260VE 3.0**
- ② — exhaust
- ③ — supply **RIS 400VE 3.0**
- ④ — exhaust
- ⑤ — supply **RIS 700VE 3.0**
- ⑥ — exhaust

		260VE 3.0	400VE 3.0	700VE 3.0
Heater	-phase/voltage [50Hz/VAC]	~1, 230	~1, 230	~1, 230
	-power consumption [kW]	1,0	2,0	3,0
Pre-heater for heat exchanger	[kW]	0,3	1,0	1,2
Fans	-phase/voltage [50Hz/VAC]	~1, 230	~1, 230	~1, 230
exhaust	-power/current [kW/A]	0,075/0,33	0,175/0,77	0,255/1,12
	-fan speed [min <sup>-1</sup> ]	1880	2100	2000
supply	-power/current [kW/A]	0,080/0,35	0,225/1,1	0,255/1,12
	-fan speed [min <sup>-1</sup> ]	1880	1850	2000
Motor protection class		IP-44	IP-44	IP-54
Thermal efficiency		55%	60%	60%
Max power consumption	[kW/A]	1,455/6,33	3,40/14,91	4,71/20,50
Automatic control		integrated	integrated	integrated
Filter class	-exhaust	G4	G4	G4
	supply	M5	M5	M5
Thermal insulation	[mm]	20	30	30
Weight	[kg]	40,0	68,0	82,0
Comply with ERP 2013		+	+	+

Designed for operation indoors only

## RIS 260VEL 3.0

Air intake side (L - left)

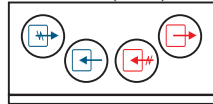

## RIS 260VER 3.0

Air intake side (R - right)

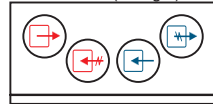

260VE 3.0	Lwa total, dB(A)	LWA, dB(A)						
		125 Hz	250 Hz	500 Hz	1 kHz	2 kHz	4 kHz	8 kHz
Supply	68	59	61	63	62	60	53	43
Extract	58	46	50	56	51	44	40	26
Surrounding	49	39	40	44	42	40	34	24

Measured at 220 m³/h, 100 Pa

## RIS 400VEL 3.0

Air intake side (L - left)

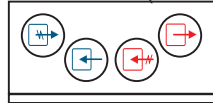

## RIS 400VER 3.0

Air intake side (R - right)

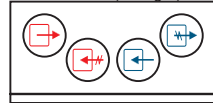

400VE 3.0	Lwa total, dB(A)	LWA, dB(A)						
		125 Hz	250 Hz	500 Hz	1 kHz	2 kHz	4 kHz	8 kHz
Supply	70	62	61	63	64	61	55	50
Extract	60	57	53	54	50	46	32	27
Surrounding	52	47	49	40	38	34	27	26

Measured at 400 m³/h, 110 Pa

## RIS 700VEL 3.0

Air intake side (L - left)

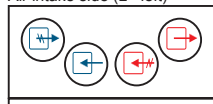

## RIS 700VER 3.0

Air intake side (R - right)

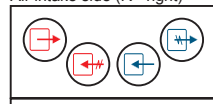

700VE 3.0	Lwa total, dB(A)	LWA, dB(A)						
		125 Hz	250 Hz	500 Hz	1 kHz	2 kHz	4 kHz	8 kHz
Supply	74	68	65	67	66	65	58	57
Extract	65	58	60	61	57	50	47	37
Surrounding	55	51	52	44	37	34	31	22

Measured at 627 m³/h, 110 Pa

View from inspection side

View from inspection side

Exhaust air
  Extract air
  Fresh air
  Supply air

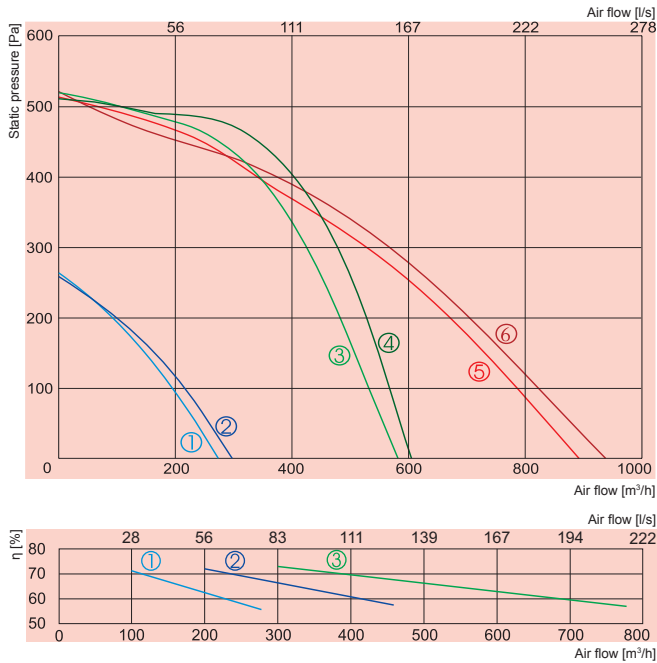

- ① — supply **RIS 260V 3.0**
- ② — exhaust
- ③ — supply **RIS 400V 3.0**
- ④ — exhaust
- ⑤ — supply **RIS 700V 3.0**
- ⑥ — exhaust

- ① — **RIS 260V 3.0**
- ② — **RIS 400V 3.0**
- ③ — **RIS 700V 3.0**

Calculated temperature efficiency (balanced mass flow) EN 13141-7:  
 Extract air = 20°C/60%RH  
 Outdoor air = -20°C

		260V 3.0	400V 3.0	700V 3.0
Water heater	-power [kW]			
	-water . T <sub>in</sub> /T <sub>ou</sub> [°C]	AVS 125	AVS 160	AVS 200
	-water pressure drop [kPa]			
Pre-heater for heat exchanger	[kW]	0,3	1,0	1,2
Fans	-phase/voltage [50Hz/VAC]	~1, 230	~1, 230	~1, 230
exhaust	-power/current [kW/A]	0,075/0,33	0,175/0,77	0,255/1,12
	-fan speed [min <sup>-1</sup> ]	1880	2100	2000
supply	-power/current [kW/A]	0,080/0,35	0,225/1,1	0,255/1,12
	-fan speed [min <sup>-1</sup> ]	1880	1850	2000
Motor protection class		IP-44	IP-44	IP-54
Thermal efficiency		55%	60%	60%
Max power consumption	[kW/A]	0,455/1,98	1,40/6,22	1,71/7,46
Automatic control		integrated	integrated	integrated
Filter class	-exhaust	G4	G4	G4
	supply	M5	M5	M5
Thermal insulation	[mm]	20	30	30
Weight	[kg]	40,0	68,0	82,0
Comply with ERP 2013		+	+	+

Designed for operation indoors only

### RIS 260VWL 3.0

Air intake side (L- left)

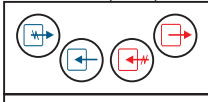

### RIS 260VWR 3.0

Air intake side (R- right)

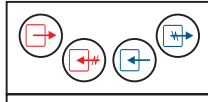

### RIS 400VWL 3.0

Air intake side (L- left)

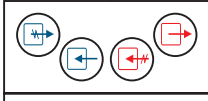

### RIS 400VWR 3.0

Air intake side (R- right)

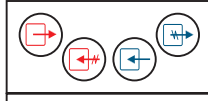

### RIS 700VWL 3.0

Air intake side (L- left)

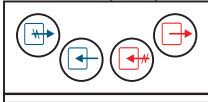

### RIS 700VWR 3.0

Air intake side (R- right)

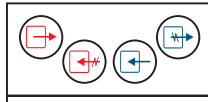

View from inspection side

View from inspection side

Exhaust air    
 Extract air    
 Fresh air    
 Supply air

260VW 3.0	Lwa total, dB(A)	LWA, dB(A)						
		125 Hz	250 Hz	500 Hz	1 kHz	2 kHz	4 kHz	8 kHz
Supply	68	59	61	63	62	60	53	43
Extract	58	46	50	56	51	44	40	26
Surrounding	49	39	40	44	42	40	34	24

Measured at 220 m³/h, 100 Pa

400VW 3.0	Lwa total, dB(A)	LWA, dB(A)						
		125 Hz	250 Hz	500 Hz	1 kHz	2 kHz	4 kHz	8 kHz
Supply	70	62	61	63	64	61	55	50
Extract	60	57	53	54	50	46	32	27
Surrounding	52	47	49	40	38	34	27	26

Measured at 400 m³/h, 110 Pa

700VW 3.0	Lwa total, dB(A)	LWA, dB(A)						
		125 Hz	250 Hz	500 Hz	1 kHz	2 kHz	4 kHz	8 kHz
Supply	74	68	65	67	66	65	58	57
Extract	65	58	60	61	57	50	47	37
Surrounding	55	51	52	44	37	34	31	22

Measured at 627 m³/h, 110 Pa

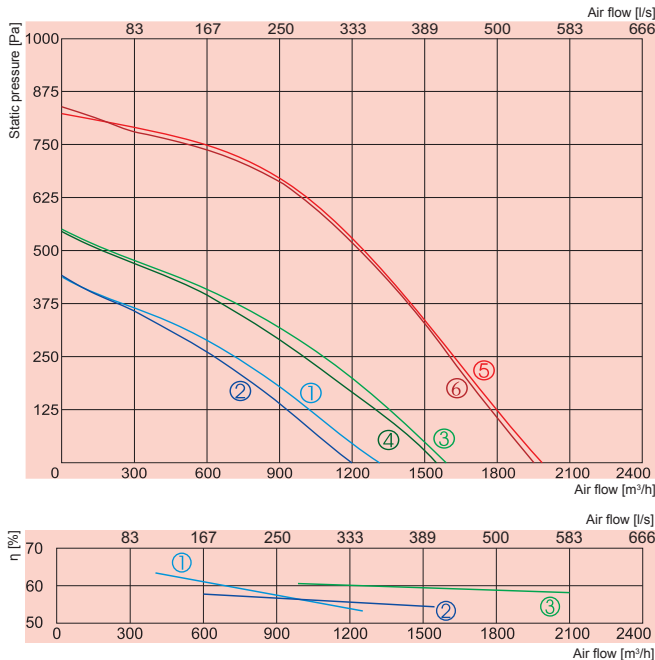

- ① — supply **RIS 1000VE 3.0**
- ② — exhaust
- ③ — supply **RIS 1500VE 3.0**
- ④ — exhaust
- ⑤ — supply **RIS 1900VE 3.0**
- ⑥ — exhaust
- ① — **RIS 1000VE 3.0**
- ② — **RIS 1500VE 3.0**
- ③ — **RIS 1900VE 3.0**

		1000VE 3.0	1500VE 3.0	1900VE 3.0
Heater	-phase/voltage [50Hz/VAC]	~3, 400	~3, 400	~3, 400
	-power consumption [kW]	6,0	9,0	15,0
Fans	-phase/voltage [50Hz/VAC]	~1, 230	~1, 230	~1, 230
exhaust	-power/current [kW/A]	0,239/1,04	0,372/1,62	0,650/2,87
	-fan speed [min <sup>-1</sup> ]	2650	2750	2830
supply	-power/current [kW/A]	0,239/1,04	0,380/1,66	0,650/2,87
	-fan speed [min <sup>-1</sup> ]	2650	2750	2830
Motor protection class		IP-44	IP-44	IP-54
Thermal efficiency		54%	54%	60%
Max power consumption	[kW/A]	6,48/9,35	9,75/14,1	16,3/23,5
Automatic control		integrated	integrated	integrated
Filter class	-exhaust	M5	M5	M5
	supply	M5	M5	M5
Thermal insulation	[mm]	50	50	50
Weight	[kg]	150,0	150,0	260,0
Comply with ERP 2013		-	-	-

Designed for operation indoors only

**RIS 1000VEL 3.0**  
Air intake side (L- left)

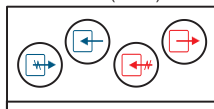

**RIS 1000VER 3.0**  
Air intake side (R- right)

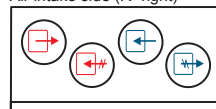

1000VE 3.0	Lwa total, dB(A)	LWA, dB(A)						
		125 Hz	250 Hz	500 Hz	1 kHz	2 kHz	4 kHz	8 kHz
Supply	78	72	74	68	70	64	56	52
Extract	64	60	61	55	50	49	42	31
Surrounding	57	51	52	49	48	45	37	32

Measured at 1039 m³/h, 120 Pa

**RIS 1500VEL 3.0**  
Air intake side (L- left)

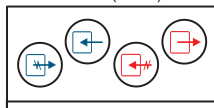

**RIS 1500VER 3.0**  
Air intake side (R- right)

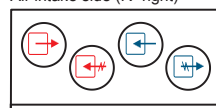

1500VE 3.0	Lwa total, dB(A)	LWA, dB(A)						
		125 Hz	250 Hz	500 Hz	1 kHz	2 kHz	4 kHz	8 kHz
Supply	80	67	73	74	75	69	66	54
Extract	68	65	62	61	58	53	45	43
Surrounding	60	52	53	54	53	49	44	39

Measured at 1366 m³/h, 120 Pa

**RIS 1900VEL 3.0**  
Air intake side (L- left)

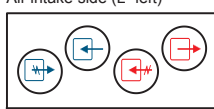

**RIRS 1900VER 3.0**  
Air intake side (R- right)



1900VE 3.0	Lwa total, dB(A)	LWA, dB(A)						
		125 Hz	250 Hz	500 Hz	1 kHz	2 kHz	4 kHz	8 kHz
Supply	86	59	76	77	80	81	76	66
Extract	70	60	63	66	64	56	50	41
Surrounding	63	47	55	57	58	57	51	44

Measured at 1819 m³/h, 120 Pa

View from inspection side

View from inspection side



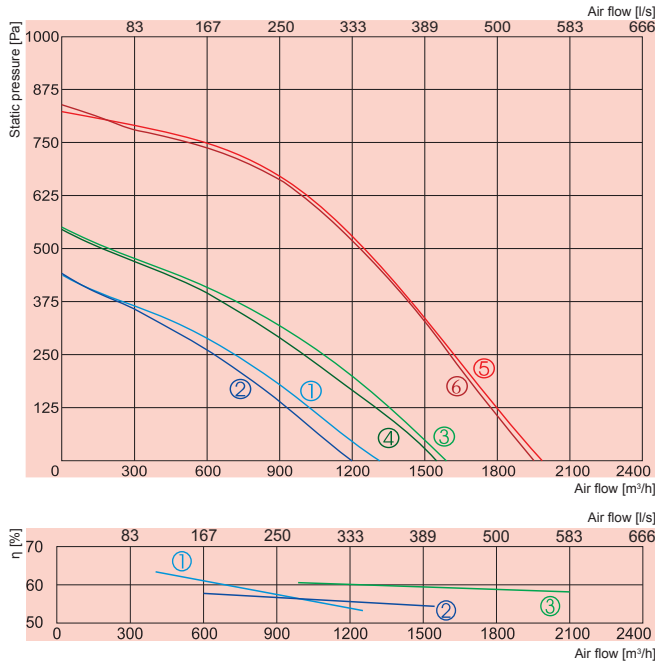

- ① — supply **RIS 1000VW 3.0**
- ② — exhaust
- ③ — supply **RIS 1500VW 3.0**
- ④ — exhaust
- ⑤ — supply **RIS 1900VW 3.0**
- ⑥ — exhaust

- ① — **RIS 1000VW 3.0**
- ② — **RIS 1500VW 3.0**
- ③ — **RIS 1900VW 3.0**

Calculated temperature efficiency (balanced mass flow) EN 13141-7:  
 Extract air = 20°C/60%RH  
 Outdoor air = -20°C

		1000VW 3.0	1500VW 3.0	1900VW 3.0
Water heater	-power [kW]	6,7	9,4	12,8
	-water temp. $T_{in}/T_{out}$ [°C]	80/60	80/60	80/60
	-water flow rate [l/s]	0,08	0,11	0,16
	-water pressure drop [kPa]	0,9	1,6	3,3
	-kvs value [m³/h]	3,1	3,2	3,2
Fans	-phase/voltage [50Hz/VAC]	~1, 230	~1, 230	~1, 230
exhaust	-power/current [kW/A]	0,239/1,04	0,372/1,62	0,650/2,87
	-fan speed [min <sup>-1</sup> ]	2650	2750	2830
supply	-power/current [kW/A]	0,239/1,04	0,380/1,66	0,650/2,87
	-fan speed [min <sup>-1</sup> ]	2650	2750	2830
Motor protection class		IP-44	IP-44	IP-54
Thermal efficiency		54%	54%	60%
Max power consumption	[kW/A]	0,478/2,08	0,752/3,27	1,3/5,65
Automatic control		integrated	integrated	integrated
Filter class	-exhaust	M5	M5	M5
	supply	M5	M5	M5
Thermal insulation	[mm]	50	50	50
Weight	[kg]	150,0	150,0	260,0
Comply with ERP 2013		-	-	-

Designed for operation indoors only

### RIS 1000VWL 3.0

Air intake side (L- left)

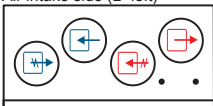

### RIS 1000VWR 3.0

Air intake side (R- right)

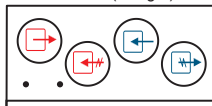

### RIS 1500VWL 3.0

Air intake side (L- left)

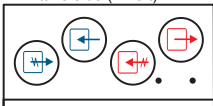

### RIS 1500VWR 3.0

Air intake side (R- right)



### RIS 1900VWL 3.0

Air intake side (L- left)

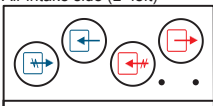

### RIRS 1900VWR 3.0

Air intake side (R- right)

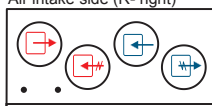

View from inspection side

View from inspection side

Exhaust air    
 Extract air    
 Fresh air    
 Supply air

1000VW 3.0	Lwa total, dB(A)	LWA, dB(A)							
		125 Hz	250 Hz	500 Hz	1 kHz	2 kHz	4 kHz	8 kHz	
Supply	78	72	74	68	70	64	56	52	
Extract	64	60	61	55	50	49	42	31	
Surrounding	57	51	52	49	48	45	37	32	

Measured at 1039 m³/h, 120 Pa

1500VW 3.0	Lwa total, dB(A)	LWA, dB(A)							
		125 Hz	250 Hz	500 Hz	1 kHz	2 kHz	4 kHz	8 kHz	
Supply	80	67	73	74	75	69	66	54	
Extract	68	65	62	61	58	53	45	43	
Surrounding	60	52	53	54	53	49	44	39	

Measured at 1366 m³/h, 120 Pa

1900VW 3.0	Lwa total, dB(A)	LWA, dB(A)							
		125 Hz	250 Hz	500 Hz	1 kHz	2 kHz	4 kHz	8 kHz	
Supply	83	60	77	78	77	75	72	63	
Extract	68	58	63	63	62	55	48	43	
Surrounding	61	46	54	56	55	54	48	43	

Measured at 1819 m³/h, 120 Pa

# RIS V

## RIS 260VE 3.0; 400VE 3.0; 700VE 3.0 (vertical) versions with electrical heater \*

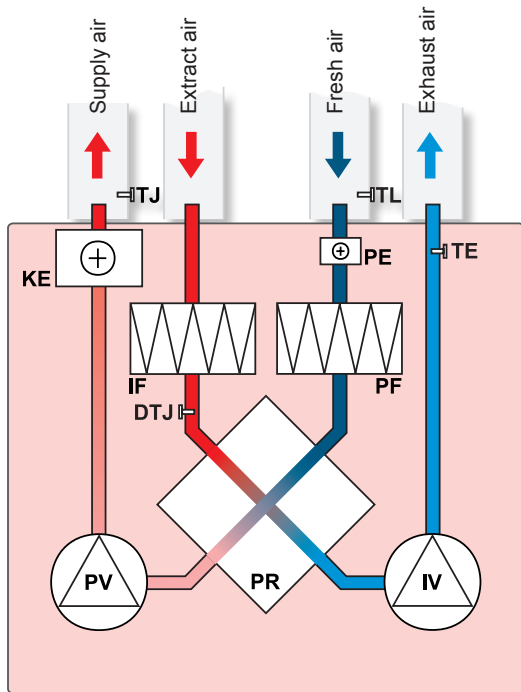

- IV - exhaust air fan
- PV - supply air fan
- PR - plate heat exchanger
- KE - electrical heater
- PE - anti-freeze heater for heat exchanger
- PF - filter for supply air (class M5)
- IF - filter for extract air (class G4)
- TJ - temperature sensor for supply air
- TL - temperature sensor for fresh air
- TE - temperature sensor for extract air
- DTJ - humidity + temperature sensor

\* - Summer cassette can be applied to all versions of RIS 260 VE 3.0; RIS 400 VE 3.0; RIS 700 VE 3.0. Used for closing-up of plate heat exchanger during warm period of the year when heat recovery is of no benefit.

## RIS 260VW 3.0; 400VW 3.0; 700VW 3.0 (vertical) versions with water heater \*

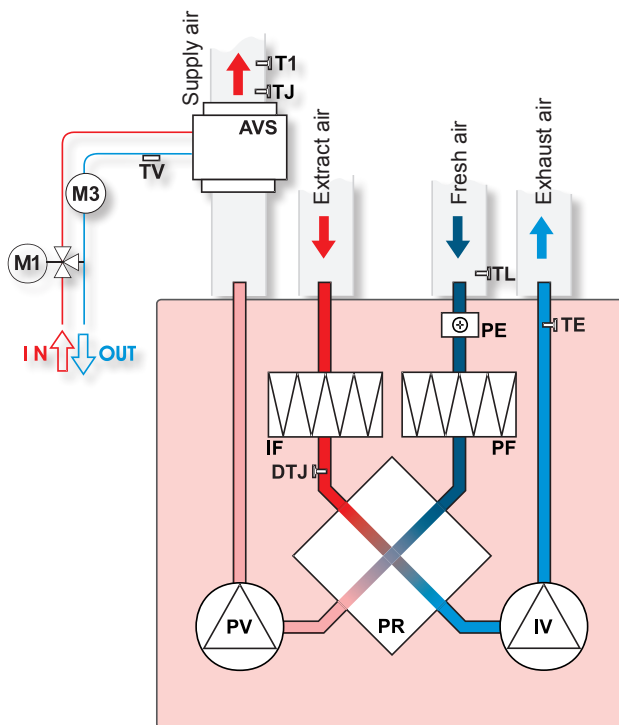

- AVS - optionally supplied water heater
- IV - exhaust air fan
- PV - supply air fan
- PR - plate heat exchanger
- PE - anti-freeze heater for heat exchanger
- PF - filter for supply air (class M5)
- IF - filter for extract air (class G4)
- TJ - temperature sensor for supply air
- TL - temperature sensor for fresh air
- TV - optionally supplied antifrost sensor
- T1 - optionally supplied antifrost thermostat
- TE - temperature sensor for extract air
- DTJ - humidity + temperature sensor
- M1 - optionally supplied mixing valve and motor
- M3 - water heater circulatory pump

This is principal mounting scheme.

\* - Summer cassette can be applied to all versions of RIS 260 VW 3.0; RIS 400 VW 3.0; RIS 700 VW 3.0. Used for closing-up of plate heat exchanger during warm period of the year when heat recovery is of no benefit.

RIS 1000VE 3.0; 1500VE 3.0; 1900VE 3.0 (vertical) versions with electrical heater

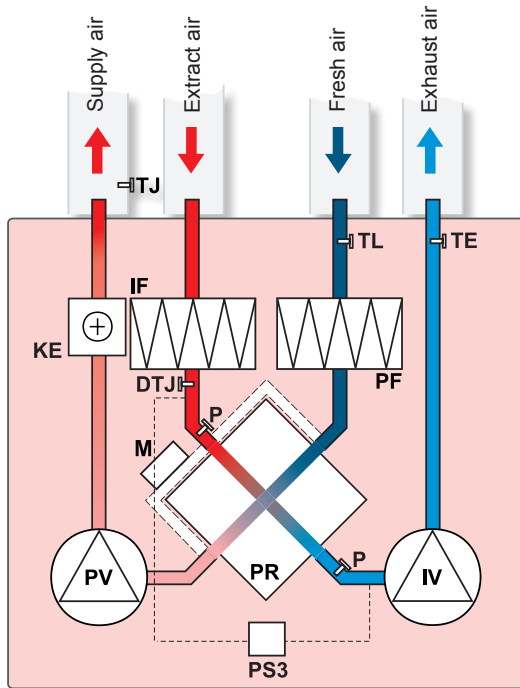

- IV - exhaust air fan
- PV - supply air fan
- PR - plate heat exchanger
- KE - electrical heater
- PF - filter for supply air (class M5)
- IF - filter for extract air (class M5)
- TJ - temperature sensor for supply air
- TL - temperature sensor for fresh air
- TE - temperature sensor for extract air
- DTJ - humidity + temperature sensor
- P - heat exchanger pressure switch
- M - by-pass damper
- PS3 - heat exchanger antifrost pressure switch

RIS 1000VW 3.0; 1500VW 3.0; 1900VW 3.0 (vertical) versions with water heater

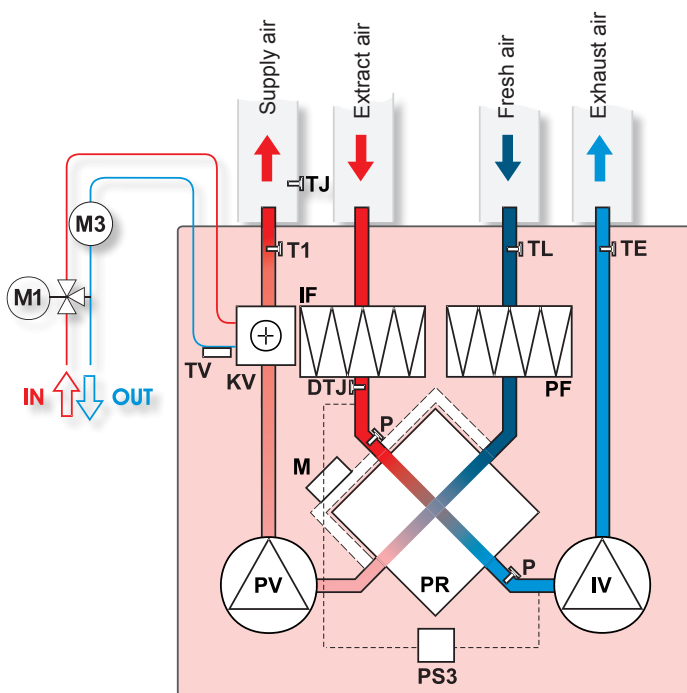

- IV - exhaust air fan
- PV - supply air fan
- PR - plate heat exchanger
- KV - water heater
- PF - filter for supply air (class M5)
- IF - filter for extract air (class M5)
- TJ - temperature sensor for supply air
- TL - temperature sensor for fresh air
- TE - temperature sensor for extract air
- DTJ - humidity + temperature sensor
- P - heat exchanger pressure switch
- T1 - antifrost thermostat
- TV - antifrost sensor
- M - by-pass damper
- M1 - optionally supplied mixing valve and motor
- M3 - water heater circulatory pump
- PS3 - heat exchanger antifrost pressure switch